

### 1.3.2 PROPOSED PATIENT INFORMATION LEAFLET

#### PATIENT INFORMATION LEAFLET

SCHEDULING STATUS: **S4**

**ONE-ALPHA CAPSULES 1 µg**

**ONE-ALPHA CAPSULES 0,25 µg**

**Alphacalcidol**

**Read all of this leaflet carefully before you start taking ONE-ALPHA**

- Keep this leaflet. You may need to read it again.
- If you have further questions, please ask your doctor, pharmacist, nurse or other health care provider.
- ONE-ALPHA has been prescribed for you personally and you should not share your medicine with other people. It may harm them, even if their symptoms are the same as yours.

#### **What is in this leaflet**

1. What ONE-ALPHA is and what it is used for
2. What you need to know before you take ONE-ALPHA
3. How to take ONE-ALPHA
4. Possible side effects
5. How to store ONE-ALPHA
6. Contents of the pack and other information

#### **1. What ONE-ALPHA is and what it is used for**

One-Alpha contains the active substance alfacalcidol.

Alphacalcidol belongs to a group of medicines called vitamin D analogues. It is a type of vitamin D.

Vitamin D controls the levels of two substances in your body. These substances are called calcium and phosphate. Your body needs both of these substances for healthy bones and teeth.

Alphacalcidol works by increasing the amount of vitamin D in your body. This means the levels of calcium and phosphate in your body will increase too.

Alphacalcidol is used to treat diseases where the amount of calcium in your body needs changing. It is used to treat:

- Changes in bone caused by kidney failure
- Changes to your parathyroid glands. These are small glands found in your neck. They make a substance called the parathyroid hormone. This changes the amount of calcium in your body.
  - The glands may make the amount of calcium in your blood too high
  - The glands may make the amount of calcium in your blood too low
- Softening and deformity of the bones due to lack of calcium

## **2. What you need to know before you take ONE-ALPHA**

### **Do not take ONE-ALPHA:**

- If you are allergic (hypersensitive) to alphacalcidol or any of the other ingredients. You can find a list of these ingredients in section 6 of this leaflet.
- If you have high levels of calcium in your blood (hypercalcaemia)
- If you know that you have a condition called calcification. This means you have high levels of calcium in your body tissues.
- If you are pregnant (First trimester)

If you are unsure if any of the above apply to you, talk to your doctor before taking ONE-ALPHA.

### **Warnings and precautions**

Tell your doctor or health care provider before taking ONE-ALPHA:

- if you have any problems with your kidneys. This includes if you have kidney stones.
- If you have granulomas or sarcoidosis. You may be more sensitive to ONE-ALPHA.

You may get too much calcium or phosphate in your blood when you take this medicine.

Please read section 4 of this leaflet so you can spot any signs this may be happening to you.

Your doctor may need to change your dose.

While you are taking ONE-ALPHA your doctor will take regular blood tests. This is very important in children, patients with kidney problems, or patients on a high dose of medicine.

This is to check the level of calcium and phosphate in your blood while you take your medicine.

- Your doctor may prescribe another medicine called a phosphate binding agent to take as well as ONE-ALPHA. This will help to keep the right amount of phosphate in your blood.
- Your doctor may also prescribe a calcium supplement to take as well as ONE-ALPHA. This is to maintain the right amount of calcium in your blood.

### **Other medicines and ONE-ALPHA**

Always tell your health care provider if you are taking any other medicine.

(This includes complementary or traditional medicines.)

You must tell your health care provider if you are taking any of the following medicines:

- Anticonvulsants (for example, barbiturates, phenytoin, carbamazepine or primidone): for epilepsy or fits. You may need a larger dose of ONE-ALPHA
- Cardiac glycosides, such as digoxin: for heart problems. You may get too much calcium in your blood. This may cause an abnormal heart beat.
- Thiazide diuretics, often called “water pills”: for increasing the amount of water (urine) that your body makes. You may get too much calcium in your blood.

- Calcium-containing medicines. You may get too much calcium in your blood.
- Other medicines that contain vitamin D. You may get too much calcium in your blood.
- Antacids containing magnesium: for heartburn or indigestion. You may get too much magnesium in your blood.
- Medicines containing aluminium. Too much aluminium is toxic.
- Bile acid sequestrants such as cholestyramine: for lowering your cholesterol level, or to help stop some types of diarrhoea or itching. Your ONE-ALPHA may not enter your blood as usual.

### **ONE-ALPHA with food and drink**

See section 3 How to take ONE-ALPHA

### **Pregnancy and breastfeeding**

If you are pregnant or breastfeeding, think you may be pregnant or are planning to have a baby, please consult your doctor, pharmacist or other health care provider for advice before taking this medicine.

### **Driving and using machines**

Usually your medicine may have very little effect on your ability to drive or use machines. Check with your doctor if you feel any side effect, for example dizziness, that may stop you from driving or using machines.

### **ONE-ALPHA contains:**

ONE-ALPHA contains:

- Sesame oil. This may rarely cause severe allergic reactions.

Please ask your doctor if you are worried about any of the ingredients in this medicine.

### 3. How to take ONE-ALPHA

Do not share medicines prescribed for you with any other person.

Always take ONE-ALPHA exactly as your doctor or pharmacist has told you. Check with your doctor or pharmacist if you are not sure.

#### How to take the capsule out of the blister

Press on the shiny side of the blister. The capsule will come out through the printed side of the foil.

Please see the diagram.

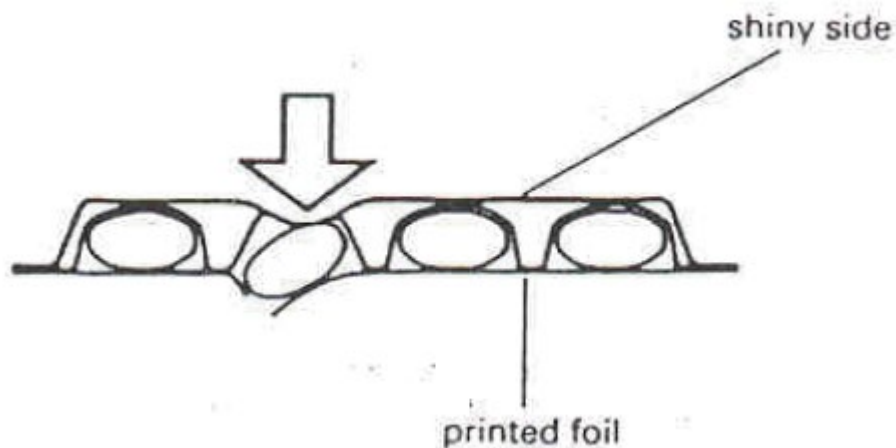

#### How much ONE-ALPHA to take

Your doctor will tell you how many capsules to take, or to give your child.

At first you will have weekly blood tests to check the levels of some substances in your blood. These tests are to check the levels of calcium, an enzyme called alkaline phosphatase or the parathyroid hormone. This is so your doctor knows that you are taking the dose that is right for you. When you are getting the correct dose, you will not need blood tests so often.

You may also have other tests such as X-rays. This is also so your doctor knows that the dose is right for you.

Your doctor may adjust your dose. Your doctor may ask you to take more or less capsules depending on your test results.

You may get too much calcium or phosphate in your blood when you take this medicine. Please read section 4 of this leaflet so you can spot any signs this may be happening to you.

Your doctor will tell you not to take any more medicine. You will need to have some blood tests. When the blood tests are normal you can start your medicine again. It is important that you only take half the dose you had before.

### **Adults and children weighing more than 20 kilograms:**

The usual starting dose is 1 microgram each day. This is either 1 brown capsule or 4 cream capsules. People usually take between 1 and 3 micrograms each day.

Most people take between 0,25 and 1 microgram each day once the blood test results show the medicine is working. This is usually one cream capsule, or one brown capsule.

If you have very low levels of calcium in your blood, your doctor may prescribe between 3 and 5 micrograms each day. Your doctor may prescribe another medicine called a calcium supplement to take as well as ONE-ALPHA. This will help to keep the right amount of calcium level in your blood.

### **Children:**

The dose depends on the weight of the child (called bodyweight).

- New-born and premature babies:

The usual starting dose is 0,05 to 0,1 microgram per kilogram of bodyweight each day.

If the level of calcium in their blood is very low, up to 2 micrograms per kilogram of bodyweight may be needed each day.

A dose of 0,1 microgram per kilogram bodyweight each day is used to stop low blood calcium levels in premature babies.

- Children weighing less than 20 kilograms:

The usual starting dose is 0,05 microgram per kilogram bodyweight each day.

### **If you take more ONE-ALPHA than you should**

In the event of overdosage, consult your doctor or pharmacist. If neither is available, contact the nearest hospital or poison centre.

You may get too much calcium or phosphate in your blood. Please read section 4 of this leaflet so you can spot any signs this may be happening to you.

### **If you forget to take ONE-ALPHA**

If you forget to take your medicine, take it as soon as you remember. Then take the next dose at the usual time.

## **4. Possible side effects**

ONE-ALPHA can have side effects.

Not all side effects reported for ONE-ALPHA are included in this leaflet. Should your general health worsen or if you experience any untoward effects while taking ONE-ALPHA, please consult your health care provider for advice.

If any of the following happens, stop taking/using ONE-ALPHA and tell your doctor immediately or go to the casualty department at your nearest hospital:

- swelling of the face, lips and mouth or throat, which may cause difficulty in swallowing or breathing,
- rash or itching,

These are all very serious side effects. If you have them, you may have had a serious reaction to ONE-ALPHA. You may need urgent medical attention or hospitalisation.

Tell your doctor immediately or go to the casualty department at your nearest hospital if you notice any of the following:

- Kidney problems:
  - Needing to pass water (urine) less often,
  - Swelling of any parts of your body,
  - Fever with a pain in your side.

Kidney stones may be forming. Kidney stones may cause a sharp spasm in one side of your lower back.

These are all serious side effects. You may need urgent medical attention.

Tell your doctor if you notice any of the following:

Common side effects:

- Abdominal/stomach pain or discomfort,
- Rash,
- Itch.

Less common side effects:

- Headache,
- Diarrhoea, vomiting, constipation, nausea,
- Muscle pain,
- Fatigue,
- Feeling weak or unwell,
- Dizziness,
- Confusion,
- Hives.



If you notice any side effects not mentioned in this leaflet, please inform your doctor or pharmacist.

### **Reporting of side effects**

If you get side effects, talk to your <doctor><or><,><pharmacist><or nurse>. You can also report side effects to SAHPRA via the “**6.04 Adverse Drug Reaction Reporting Form**”, found online under SAHPRA’s publications:

<https://www.sahpra.org.za/Publications/Index/8>. By reporting side effects, you can help provide more information on the safety of ONE-ALPHA.

For reporting of side effects directly to the HCR, contact +27 11 635 0134 or email [Adcock.aereports@adcock.com](mailto:Adcock.aereports@adcock.com).

### **5. How to store ONE-ALPHA**

Store all medicines out of reach of children.

Capsules: Protect from direct sunlight and heat.

Store at or below 25 °C.

Return all unused medicine to your pharmacist.

Do not dispose of unused medicine in drains or sewerage systems (e.g. toilets).

### **6. Contents of the pack and other information**

#### **What ONE-ALPHA contains**

- The active ingredient is alphacalcidol.

ONE-ALPHA CAPSULES 1 µg soft gelatin capsules containing 1 µg of alphacalcidol (1 α-hydroxyvitamin D3)

ONE-ALPHA CAPSULES 0,25 µg soft gelatin capsules containing 0,25 µg of alphacalcidol (1 α-hydroxyvitamin D3)

- The other ingredients are:

ONE-ALPHA CAPSULES 1 µg:

Excipients: Sesame oil

Antioxidant: All-*rac*-α-tocopherol

Capsule shell: Gelatin, glycerol, potassium sorbate, black iron oxide (E172) and red iron oxide (E172)

ONE-ALPHA CAPSULES 0,25 µg:

Excipients: Sesame oil

Antioxidant: All-*rac*-α-tocopherol

Capsule shell: Gelatin, glycerol, potassium sorbate and titanium dioxide (E171)

**What ONE-ALPHA looks like and contents of the pack**

**ONE-ALPHA CAPSULES 1 µg**

Brown-coloured and egg-shaped soft gelatin capsules in a tamper evident strip-blister pack of 30 capsules.

**ONE-ALPHA CAPSULES 0,25 µg**

Cream-coloured and egg-shaped soft gelatin capsules in a tamper evident strip-blister pack of 30 capsules.

**Holder of Certificate of Registration**

Adcock Ingram Critical Care (Pty) Ltd.

1 Sabax Road,

Aeroton,

Johannesburg,

2013

Tel: +27 11 494 8000

**This leaflet was last revised in**

13 June 2022

**Registration numbers**

ONE-ALPHA CAPSULES 1 µg: M/22.1.4/0261

ONE-ALPHA CAPSULES 0,25 µg: M/22.1.4/0262

Details of Registration in SSA countries

ONE-ALPHA CAPSULES 1 µg:

NA: NS2 90/22.1.4/00192

BW: S2 B9300665

ONE-ALPHA CAPSULES 0,25 µg:

NA: NS2 90/22.1.4/00191

BW: S2 B9300660